

Effect of Waveform in Haptic Perception of Electro vibration on Touchscreens

Yasemin Vardar¹, Burak Güçlü², and Cagatay Basdogan¹

¹Koç University, College of Engineering, Robotics and Mechatronics Laboratory, Rumeli Feneri Yolu, 34450, Sarıyer, Istanbul, Turkey
{yvardar13, cbasdogan}@ku.edu.tr

²Boğaziçi University, Institute of Biomedical Engineering, Tactile Research Laboratory, Kandilli Campus, 34335, Çengelköy, Istanbul, Turkey
burak.guclu@boun.edu.tr

Abstract. *The perceived intensity of electro vibration can be altered by modulating the amplitude, frequency, and waveform of the input voltage signal applied to the conductive layer of a touchscreen. Even though the effect of the first two has been already investigated for sinusoidal signals, we are not aware of any detailed study investigating the effect of the waveform on our haptic perception in the domain of electro vibration. This paper investigates how input voltage waveform affects our haptic perception of electro vibration on touchscreens. We conducted absolute detection experiments using square wave and sinusoidal input signals at seven fundamental frequencies (15, 30, 60, 120, 240, 480 and 1920 Hz). Experimental results depicted the well-known U-shaped tactile sensitivity across frequencies. However, the sensory thresholds were lower for the square wave than the sinusoidal wave at fundamental frequencies less than 60 Hz while they were similar at higher frequencies. Using an equivalent circuit model of a finger-touchscreen system, we show that the sensation difference between the waveforms at low fundamental frequencies can be explained by frequency-dependent electrical properties of human skin and the differential sensitivity of mechanoreceptor channels to individual frequency components in the electrostatic force. As a matter of fact, when the electrostatic force waveforms are analyzed in the frequency domain based on human vibrotactile sensitivity data from the literature [15], the electro vibration stimuli caused by square-wave input signals at all the tested frequencies in this study are found to be detected by the Pacinian psychophysical channel.*

Keywords: Waveform, Electro vibration, Perception, Electrostatic Forces, Square, and Sinusoidal Waves

1 Introduction

Surface haptics has recently gained a growing interest by the haptics community due to the popularity of touch screens used in a variety of electronic devices. The current studies on surface haptics have focused on displaying efficient tactile feedback to a user as the user moves her/his finger on the screen. One approach to generating tactile effects through a touch surface is to control the friction force between fingertip of the user and the surface using electrostatic actuation [26], [20], [28]. If an alternating voltage is applied to the conductive layer of a touchscreen, an attraction force is created between the finger and the surface. This force modulates the friction between the surface and the skin of the moving finger. By controlling the amplitude, frequency and waveform of this input voltage, different texture feelings can be generated on the touchscreen [26], [11].

Creating haptic effects using electrostatic attraction was first utilized by Strong and Troxel [27]. In their study, they developed an electro tactile display consisting of an

array of pins insulated with a thin layer of dielectric. Using friction induced by electrostatic attraction force, they generated texture sensations on the display surface. Their experimental results showed that the intensity of texture sensation was primarily due to the peak intensity of the applied voltage rather than to the current density. Later, Beebe et al. [13], developed a polyimide-on-silicon electrostatic fingertip tactile display using lithographic microfabrication. They were able to create texture sensations using 200-600 V pulse excitations on this thin and durable display and reported perception at the fingertip as "sticky." In a following study, Tang and Beebe [18] performed experiments of detection threshold, line separation and pattern recognition on visually impaired subjects. Although they encountered problems such as dielectric breakdown and sensor degradation, the subjects were able to differentiate simple tactile patterns by haptic exploration. Agarwal et. al [1] continued these human detection threshold experiments and tested the effect of dielectric thickness in haptic perception during electrostatic stimulation. Their results showed that variations in dielectric thickness did not have a linear impact on the threshold voltage. Following this study, Kaczmarek et al. [21] explored the perceptual sensitivity to positive and negative input pulses. Their results showed that the subjects perceived negative or biphasic pulses better than positive ones. In all of these studies, electro-vibration was obtained using opaque patterns of electrodes on small scale surfaces. However, in the recent works of Bau et al. [26] and Linjama et al. [20], electro-vibration was delivered via a transparent electrode on a large and commercial touch surface, which demonstrates the viability of this technology on mobile applications. Wijekoon et al. [11], followed the work of [20], and investigated the perceived intensity of modulated friction created by electro-vibration. Their experimental results showed that the perceived intensity was logarithmically proportional to the amplitude of the applied signal and dependent on the frequency.

Although electro-vibration can provide rich tactile sensation opportunities, little work has been done on creating realistic texture sensations using this method. One of the main reasons for this is the difficulty of measuring the electrostatic force between the human fingertip and the touch surface. Due to its small magnitude, it is difficult to measure the electrostatic attraction force using the force transducers commercially available today. To understand how mechanical forces develop at the fingertip-surface interface, Meyer et al. [10], developed a tribometer and measured the lateral force to estimate the electrostatic attraction force for the applied voltage. They showed the effect of actuation frequency on the lateral frictional force despite some subject-dependent variability. They reported that this person to person variability depends on varying environmental impedances which are caused by voltage controlled electro-vibration. Later, Vezzoli et al. [14] improved the model of electro-vibration by including frequency-dependent electrical properties of human skin as documented in [30]. Recently, Kim et al. [16], developed a current control method to solve the non-uniform intensity perceived by the subjects, reported in the earlier studies. The results of their user study show that the proposed current control method can provide significantly more uniform perceived intensity of electro-vibration than voltage controlled one.

The earlier studies showed that displaying textures realistically on a touch screen is not straightforward since the human finger show complex frequency-dependent mechanical and electrical properties. Moreover, human to human variability of these properties further complicates the problem. For example, both the electrical and mechanical impedances of the human finger are frequency-dependent and the coupling between them has not been well understood yet. The existing model explaining the electrostatic forces developed between fingertip and touchscreen shows that electrostatic force depends on the amplitude and frequency of the input voltage (see Section 2.1). Even though the effects of these two parameters on human tactile perception have already been investigated using pure sine waves, there is no early study on how our perception changes

when another waveform is used. Therefore, we explore how input voltage waveform alters human haptic perception in this paper. This work was particularly motivated by our initial observation that square-wave excitation causes stronger tactile sensation than the sine-wave excitation, although the electrostatic force generated by square-wave appears to be constant according to the existing model (see Section 2.1). In this model, the electrostatic force is a function of the square of the input voltage signal, hence the electrostatic force becomes constant when the input voltage is a square wave. Since DC (constant) excitation voltages and constant electrostatic forces do not cause vibration sensation (although they cause adhesion sensation [9]), the square wave excitation is expected to be filtered electrically by the stratum corneum as suggested as in the previous work [10], [14].

In this paper using a simulation model developed in Matlab-Simulink, we first show that the forces transmitted to the human finger by electro-vibration are very different for square and sinusoidal input voltages at low fundamental frequencies due to electrical filtering. We then support this claim by presenting the results of psychophysical experiments conducted with 8 human subjects. The results indicate that the human finger is more sensitive to a square wave than sinusoidal wave at fundamental frequencies lower than 60 Hz. We conclude that the Fourier frequency components in the electrostatic force, generated by the filtered square wave excitation signal, are typically high (> 200 Hz) and activate the Pacinian psychophysical channel [2], [25].

2 Electro-vibration with Waveform Analysis

2.1 Reinterpretation of Electrostatic Force

Based on the parallel plate capacitor theory, the attractive force between two plates is expressed as

$$F = \frac{\epsilon_0 \epsilon_i A V^2}{2d^2}, \quad (1)$$

where ϵ_0 is permittivity of vacuum, ϵ_i is relative permittivity of the insulator, V is applied voltage (can be time varying), A area of the plates and d is the thickness of the insulator, [12]. Electrostatic forces are developed at the boundaries of the two dielectrics: stratum corneum and insulator. If a human finger on a touch surface is represented in Figure 1a, the electrostatic force which effects the fingertip can be expressed as

$$F_e = \frac{\epsilon_0 \epsilon_{sc} A}{2} \left(\frac{V_{sc}}{d_{sc}} \right)^2, \quad (2)$$

where ϵ_{sc} is relative permittivity of the stratum corneum, A the area of the fingertip, d is the thickness of the stratum corneum and V_{sc} is the voltage to across the stratum corneum. V_{sc} can be expressed in terms of the applied voltage as

$$V_{sc} = V \frac{Z_{sc}}{Z_{body} + Z_{sc} + Z_{surface}}, \quad (3)$$

where Z_{body} , Z_{sc} and $Z_{surface}$ represents the impedances of the human body, stratum corneum, and tactile surface respectively. Even though Shultz et al. state in [9] that the air gap between the fingertip and the touch surface has a substantial effect in the created electrostatic force, we neglect the impedance of the air in this model for simplification purposes.

Equation 2 may look slightly different than the electrostatic force formulas defined in [10] and [14]. In those articles, the total electrostatic force created between the conductive

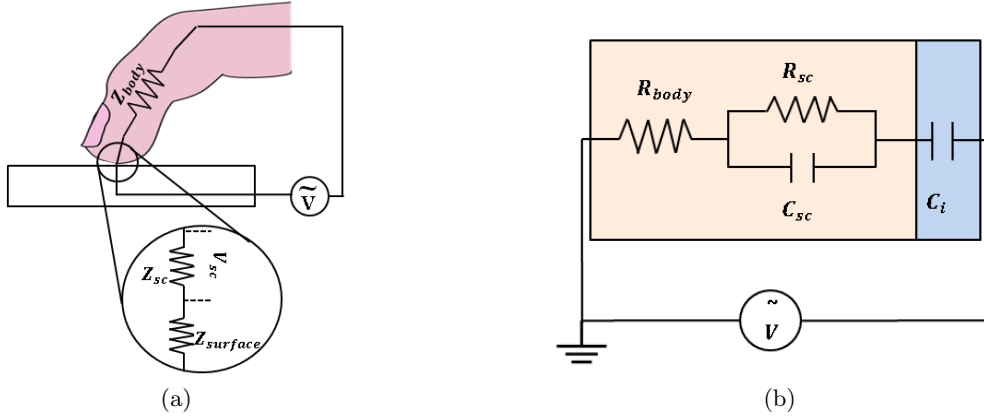

Fig. 1: a. Equivalent circuit model of human finger on a touch surface. b. The simplified equivalent circuit model of human finger on a touch surface.

layer of the touch surface and the conductive layer of the finger is represented as the perceived electrostatic force. However, in our opinion, it is more reasonable to represent the perceived effects due to the electrostatic force at the inner boundary of the stratum corneum, because the mechanoreceptors are located close to the epidermal junction or in the dermis, [8], [5], [3]. Therefore, V_{sc} and not V is used in our calculations. For more information related to the derivation of the electrostatic force created on the boundaries of two parallel or series dielectrics, the reader may refer to [22].

2.2 Waveform Analysis of Electro vibration

To investigate the effect of waveform in electro vibration, we develop an equivalent circuit model of human finger (see Figure 1a) in Matlab-Simulink environment. The model here is simplified, and the capacitance of the human body and the internal resistance of the touch surface are neglected. Also, the finger is simply modelled as resistance and capacitance in parallel as shown in Figure 1b. The parameters used in Figure 1b and their values used in the Matlab simulation are given in Table 1. The human resistance is approximated as $1\text{ k}\Omega$ [16]. Vezzoli et al. show that intensity of electro vibration is highly frequency-dependent [14]. In their model, they use frequency-dependent values of resistivity, ρ_{sc} , and dielectric constant, ϵ_{sc} , of human stratum corneum as reported in [30]. Likewise, we fit mathematical functions to the experimental data reported by [30] and use these functions in our Matlab simulations (see Figure 2a). Using Equation 3, the relation between input voltage, V , and the voltage across stratum corneum, V_{sc} , is written as

$$\frac{V_{sc}}{V} = \frac{R_{sc}C_i s}{s^2(R_{body}C_i R_{sc}C_{sc}) + s(R_{body}C_i + R_{sc}C_i + R_{sc}C_{sc}) + 1}. \quad (4)$$

Figure 2b represents the Bode plot of the system. It appears that the system shows the behaviour of a bandpass filter with cut-off frequencies, f_{low} , and, f_{high} , at approximately 1 kHz and 20 kHz. Hence, the system shows first order high pass filter behaviour at low frequencies. To test the effects of signal filtering, we perform simulations with two different input waveforms (sinusoidal and square) at two fundamental frequencies (15 and 480 Hz). Figure 3a shows the applied input voltage signals in simulations. Figure 3b shows the filtered signals, in other words, the voltage across the stratum corneum.

Table 1: The description of parameters used in the circuit model shown in Figure 1b and their values used in the Matlab simulations.

Parameter	Explanation	Value	Unit
A	Area of human fingertip	0.1	cm^2
ϵ_0	Permittivity of vacuum	$8.854 * 10^{-12}$	F/m
R_{body}	Resistance of human body	1	$k\Omega$
C_i	Capacitance of the insulator of 3M MicroTouch	$C_i = \frac{\epsilon_0 \epsilon_i A}{d_i}$	$farad$
ϵ_i	Relative permittivity of the insulator	3.9	-
d_i	Thickness of the insulator	1	μm
R_{sc}	Resistance of stratum corneum	$R_{sc} = \frac{\rho_{sc} d_{sc}}{A}$	Ω
C_{sc}	Capacitance of stratum corneum	$C_{sc} = \frac{\epsilon_0 \epsilon_{sc} A}{d_{sc}}$	$farad$
ρ_{sc}	Resistivity of stratum corneum	Figure 2a	Ωm
ϵ_{sc}	Relative permittivity of stratum corneum	Figure 2a	-

When the input is a low frequency (15 Hz) sinusoidal signal, the output signal is phase-shifted and its amplitude drops significantly, whereas the drop in the output amplitude is much less for the high frequency sinusoidal signal at 480 Hz, as expected from high pass filtering. For the square wave at a low fundamental frequency of 15 Hz, the output has exponentially decaying low amplitude transients. As the fundamental frequency of the square wave is increased to 480 Hz, the output resembles the input more because the signal alternates fast enough that the exponential decay is not complete. The results show that, even though the touch screen is excited with an input having a certain amplitude and waveform, our mechanoreceptors may be stimulated with a different waveform and amplitude (see Figure 4a).

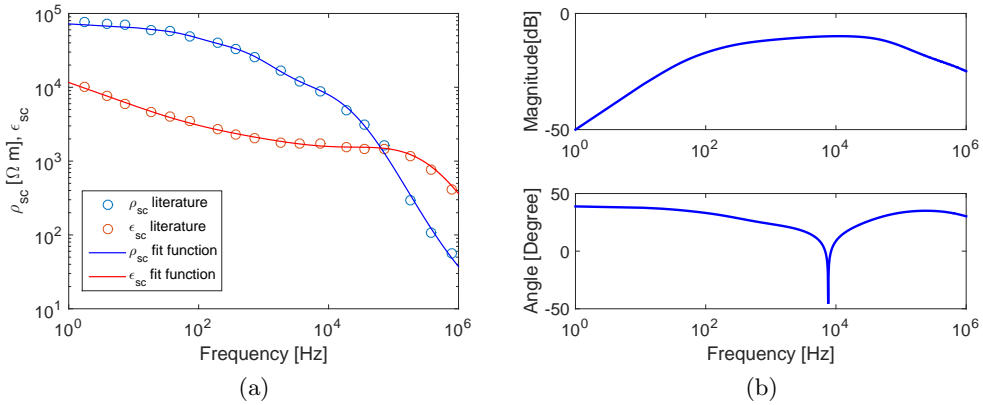

Fig. 2: a. The resistivity and dielectric constant of epidermal stratum corneum by [30] and the polynomial functions fitted by us on the experimental data points. b. Bode plot of the transfer function $\frac{V_{sc}}{V}$.

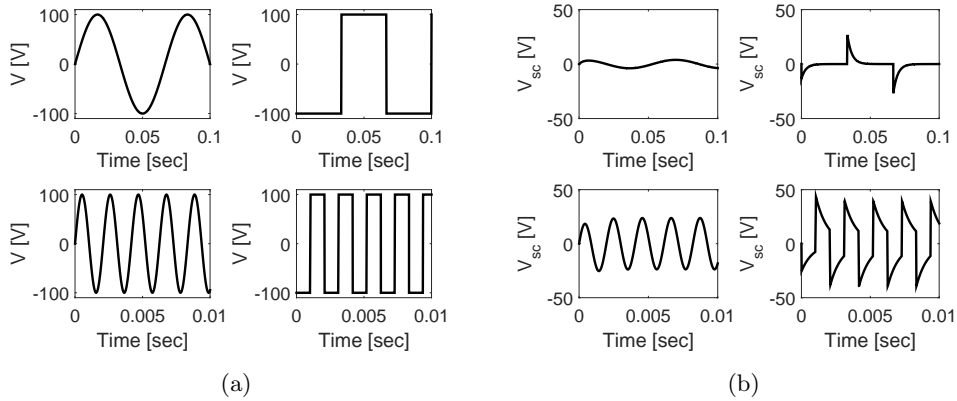

Fig. 3: a. The input voltage signals used in Matlab/Simulink simulations; sinusoidal and square signals at 15 Hz (first row) and 480 Hz (second row). b. The resulting voltage on the stratum corneum, V_{sc} , for the four cases.

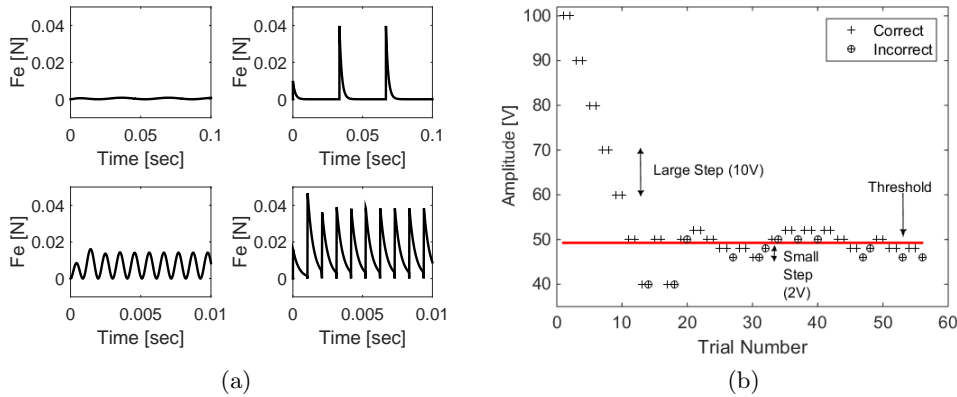

Fig. 4: a. The resulting electrostatic force across stratum corneum, F_e , for the four cases, calculated by Equation 2. b. Illustration of absolute detection threshold experiment utilizing one-up/two-down adaptive staircase method. The large and small steps and the estimated threshold are marked on the figure.

3 Experiments

To investigate how the detection of electro-vibration varies with input waveform and fundamental frequency, we conduct psychophysical experiments. As explained above, due to the electrical filtering of the system, different waveforms induce different output voltages on the stratum corneum of the user. Absolute detection threshold experiments determine the minimum stimulus amplitude that the observer can barely detect, [31], [6], [24], [2]. According to the filtering model explained in Section 2.2, this threshold is expected to be different especially at low frequencies for square and sinusoidal signals. However, since human sensitivity also changes as a function of frequency [7], [2], [24], one must also study the Fourier (frequency) components in the resultant force waveform to better interpret the experimental results.

The experimental setup used for the absolute threshold experiment is shown in Figure 5a. A touchscreen (SCT3250, 3M Inc.) is placed on top of an LCD screen. There is a computer monitor in front of the subjects to enter their response. On top of the 3M glass, an IR frame is placed to determine the location of the finger. The 3M screen is excited with a signal generated by a DAQ card (PCI-6025E, National Instruments Inc.). The voltage from the card is amplified by an amplifier (E-413, PI Inc.) before transmitted to the touch screen. The subjects' arms are supported by the arm rest during the experiments. Subjects are asked to put on head phones displaying white noise.

Absolute detection thresholds are estimated for seven input frequencies: 15, 30, 60, 120, 240, 480 and, 1920 Hz. The frequency interval is chosen specifically to show the perception differences caused by input waveform for a large range of fundamental frequencies. The two-alternative-forced-choice method is used to determine the threshold levels. This method enables bias-free experimental results [2]. Two regions are displayed to the subjects on the LCD screen and they are asked to find the region where there is a tactile stimulus. The amplitude of the tactile stimulus is changed by using one-up/two-down adaptive staircase method. This procedure decreases the number of trials and duration of the experimentation [2], [7], [24], [17], [23]. Levitt et al. state in [17] that, one-up/two-down procedure tracks thresholds at 70% correct probability of detection.

The experiments are conducted with 8 subjects (4 female, 4 male) with an average age of 27.5 (SD: 1.19). Only one of the subjects is left-handed. All of them are engineering Ph.D. students and have some experience with electrovibration.

As seen in Figure 5a, the touch screen is divided into two marked areas as A and B. The tactile stimulus is presented only in one of the two areas. The stimulus location is randomized. The finger position of the subject (whether her/his finger is in the area A or B) is detected via the IR frame. The subject is asked to explore both areas consecutively and choose the one which has a tactile stimulus.

Each session starts with the stimulus amplitude of 100 V. This initial voltage amplitude provides sufficiently high intensity stimulus for all the subjects. If the subject gives two consecutive correct answers, the voltage amplitude is decreased by 10 V. If the subject has one incorrect response, the stimulus intensity is increased by 10 V. The change

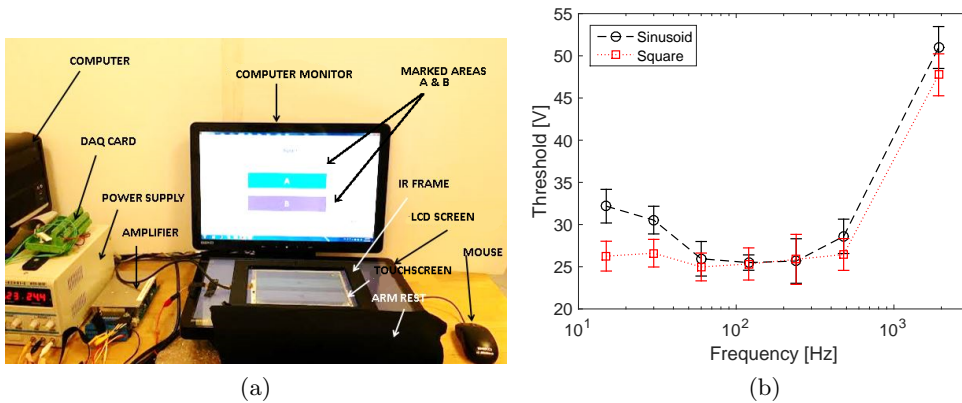

Fig. 5: a. Illustration of the experimental setup used in absolute threshold detection experiments. b. Absolute detection thresholds for seven fundamental frequencies and two waveforms, sinusoidal (black) and square (red), with their mean and standard deviation errorbars.

of the responses from correct to incorrect or the opposite is counted as one reversal. After four reversals, the step size is decreased by 2 V to have more precise threshold value as suggested in [26]. The experiment is stopped after 18 reversals. The average of the last 15 reversals gives the estimated absolute detection threshold value. For an illustration of this procedure, see Figure 4b. Each session takes approximately 15-20 minutes. The total duration of the experiment for each subject is approximately 4 hours.

4 Results

The absolute detection thresholds for seven fundamental frequencies (15, 30, 60, 120, 240, 480, 1920 Hz) and two different waveforms (sinusoidal and square) are shown in Figure 5b.

The results were analyzed by using two-way ANOVA with repeated measures. There was statistically significant main effects of both frequency and waveform on the threshold levels ($F(6,42) = 306.7$, $p < 0.001$ and $F(1,7) = 80$, $p < 0.01$). These results indicate that the threshold levels depended on both stimulus frequency and waveform. Also, there was a statistically significant interaction between frequency and waveform ($F(6,42) = 7.4$, $p < 0.01$). Therefore, the amount of differences in measured thresholds for different waveforms changed at different frequencies.

Additionally, the effect of waveform for each frequency was analyzed by using Bonferroni corrected paired t-tests. The results showed that there was a statistically significant effect of the waveform on our haptic perception for fundamental frequencies less than 60 Hz. At frequencies greater than and equal to 60 Hz, the difference between square and sinusoidal waves were not significant. The corrected p-values for each frequency (15, 30, 60, 120, 240, 480, 1920 Hz) were 0.008, 0.016, 1, 1, 1, 0.168, 0.128 respectively.

To investigate which psychophysical tactile channel was activated during each stimulus, the corresponding electrostatic forces, F_e , were calculated using measured mean threshold values and Equation 2. In other words, the voltage waveform with amplitudes equal to the threshold values was first filtered by Equation 3 and then the electrostatic

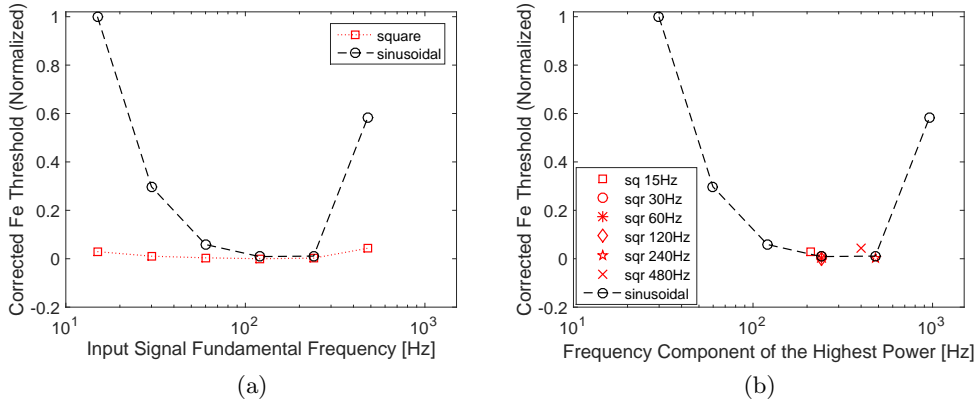

Fig. 6: The electrostatic force detection thresholds (F_e is first corrected with human sensitivity curve taken from [15] and then normalized) for sinusoidal (black) and square (red) waveforms. a. The data is plotted as a function of fundamental frequency. b. The data is plotted as a function of the frequency component with the highest power. Note: The detection thresholds for 1920 Hz are not plotted because there is not any data for this frequency in the human sensitivity curve in [15].

force was calculated. Then, the Fast Fourier Transform (FFT) magnitude of the corresponding F_e was weighted by the normalized human sensitivity curve taken from [15]. The maximum peak of this corrected FFT magnitude represents the frequency component detected by the psychophysical channel with the lowest threshold at that frequency. Figures 6a and 6b show normalized electrostatic force threshold values (corrected for the human sensitivity curve) for sinusoidal and square input signals. In Figure 6a, the threshold values are plotted as a function of the fundamental frequency of the input. In Figure 6b, they are plotted as a function of the frequency component with the highest power.

5 Discussion

The absolute detection threshold values for both waveforms resemble the well known U-shaped human sensitivity curve as shown in Figure 5b. Here, the threshold values are low between 60 Hz and 240 Hz, and higher for the rest. The results are consistent with the existing literature [2], [24], [15], [29]. In these studies, vibratory stimulus detection thresholds of the index or middle finger were measured as a function of frequency by using various contactors. However, our experimental results should be interpreted based on the frequency components with the highest power in the corrected electrostatic force signal [15], [29]. Vibrotactile studies in the literature used sinusoidal displacement stimuli with slow onsets and offsets, which created mechanical excitation with a single frequency component. However, the excitation voltage applied to the touchscreen is first filtered electrically by Equation 3 and the filtered voltage across the stratum corneum (or possibly the entire epidermal layer) generates an electrostatic force according to Equation 2. This nonlinear transformation of the signal introduces frequency components not presented in the filtered signal. Specifically, when a pure sine wave is applied to the touchscreen, the force waveform will have twice the frequency of the sine wave due to the second power in Equation 2. Therefore, when we plotted the thresholds with the sinusoidal excitation according to 2ω (Figure 6b), we obtained almost a perfect match with the human sensitivity curve [15], [29], [2], [24]. This U-shaped region originates from the activation of the Pacinian psychophysical channel.

In [26], Bau et al. measured absolute detection thresholds for sinusoidal inputs. Their results also show a U-shaped trend, but their detection threshold values for sinusoidal inputs were slightly lower than our results. This difference may be caused by environmental factors, the number of the test subjects and the person-to-person variability in the physical factors as explained in Section 2.1. Maintaining good stimulus control is essential in psychophysical experiments. Although the excitation voltage was well controlled in our experiments, contact force was not controlled. Higher contact forces would increase contact area and decrease thresholds due to spatial summation in the Pacinian channel [4]. Another limitation was regarding the simulations of the electrical filtering step. We used the values of the human skin parameters (ρ_{sc} and ϵ_{sc}) at the fundamental frequency of the input signals. Although this is valid for the sine wave, it is a simplification for the square wave, since square wave contains many frequency components. We plan to correct this in our future work by measuring the electrical impedance directly.

If a complex waveform, i.e. one which has many frequency components, is applied to the touchscreen, the frequency components in the range of 100-150 Hz would be mostly effective in psychophysical detection due to the high sensitivity of Pacinian channel at twice these frequencies. For example, due to the electrical filtering of a square wave excitation at the touchscreen-biological tissue interface, low-frequency components would be suppressed. Therefore, the voltage across the dielectric layer would include exponentially decaying transients. The electrostatic force generated based on these transients is rather complex, including twice the frequencies and distortion products of the filtered signal components. The frequency components in the force waveform would not be equally

effective because human sensitivity changes as a function of frequency. We found these resultant components by Fourier analysis and weighted them according to human sensitivity. When the data was plotted as a function of the frequencies of these components in the force waveform, and not as a function of the fundamental frequency of the excitation voltage applied to the touchscreen, the results were remarkable (compare Figures 6a and 6b). All the square wave excitation stimuli used in our experiments generated force waveforms which have frequency components of the highest power in the range of 200-500 Hz. This frequency interval again is in the detection range of Pacinian channel. Therefore, all our stimuli tested in psychophysical experiments were detected mainly by the Pacinian channel [2], [24]. Pacinian channel is the most sensitive psychophysical channel in that range, compared to the remaining three non-Pacinian channels mediated by the mechanoreceptors in the skin [29], [15]. It should be noted that the mechanical stimuli induced by electrovibration are not exactly like vibrotactile stimuli used in the previous psychophysical experiments. For example, Summers et al. [19], found that vibrotactile sine waves and monophasic/tetra-phasic pulses at supra-threshold levels resulted in similar identification scores in a frequency identification task. They concluded that temporal cues are more important than spectral cues in that particular task. Although their psychophysical task is very different, the ineffectiveness of spectral cues and their variation somewhat supports our argument that the strongest frequency component in complex waveforms (after correction for human sensitivity) determines the psychophysical channel for detection. The spectral contents of the stimuli used in their study would activate the Pacinian channel mostly as well.

6 Conclusion

In this paper, we conducted psychophysical studies with 8 human subjects and showed that human finger is more sensitive to a square wave than sinusoidal wave at fundamental frequencies lower than 60 Hz. Using equivalent circuit model of finger-surface system developed in Matlab-Simulink, we showed that sensation difference of waveforms in low fundamental frequencies could be explained by frequency-dependent electrical properties of human skin and human tactile sensitivity. The tactile sensation generated by electrovibration depends on the frequency components in the input waveform. This input waveform passes through a filter and a nonlinear transfer function (see Equation 2) and arrives into mechanoreceptors. Since this resultant waveform is rather complex and contains many frequency components, it may activate different psychophysical channels at different threshold levels [29], [15]. These four psychophysical channels (NPI, NPII, NPIII, P) are mediated by four corresponding mechanoreceptors which enable the tactile perception. To predict tactile sensitivity to a complex stimulation, the Fourier components of the stimulation should be weighted by the inverse of human sensitivity curve [15]. The tactile perception occurs at the channel in which the maximum of this weighted function located. In our study, we found that the Fourier frequency components in the electrostatic force, generated by the filtered square-wave excitation signal, are typically high (> 200 Hz) and activate the Pacinian psychophysical channel [2], [25] for tactile detection.

Even though our approach can predict the experimental results qualitatively, the correct electrostatic force can be calculated with a proper measurement of the electrical impedances in the entire system. Moreover, we have not investigated the effect of normal force and finger velocity on our results. When there is no relative movement between the surface and the finger, the electrostatic force, albeit varying in time with sinusoidal excitation, does not generate a vibration sensation. It is generally accepted that the electrostatic force changes the normal force, and thus friction during movement. The mechanoreceptors in the skin are probably excited by shear forces modulated by friction.

Therefore, a physically accurate explanation of electro-vibration can only be obtained by an electromechanical model linking the electrostatic force generation at the tissues and the mechanical forces during movement. For future work we aim to 1) measure the electrical impedance of subjects who participated in the experiments and estimate the resulting electrostatic force more accurately, 2) investigate the effect of normal force and finger velocity during experiments, and 3) extend our electrical model by combining it with the mechanical properties of the finger.

7 Acknowledgements

The Scientific and Technological Research Council of Turkey (TUBITAK) supported this work under Student Fellowship Program BİDEB-2211. Also, Y.V would like to first thank Prof. Dr. Ozgur Birer for his valuable comments during discussions. Moreover, Y.V would like to acknowledge Ozan Caldiran, Gokhan Serhat, Amir Reza Aghakhani, Omer Sirin, and Utku Boz for their valuable comments and technical help during this study. Moreover, Y.V would like to acknowledge the initial help and support given by Ezgi Emgin and Enes Selman Ege. They introduced electro-vibration to Y.V. and provided a quick start for her study. Also, Y.V would like to thank all subjects who participated in the experiments.

References

1. Agarwal A. K., Namni K., Kaczmarek K. A., Tyler M. E., and Beebe D. J. A hybrid natural/artificial electrostatic actuator for tactile stimulation. In *Proc. of the 2nd Annual Conference on Microtechnologies in Medicine and Biology*, pages 341–345, Madison, Wisconsin USA, 2002.
2. Güçlü B. and Öztekin C. Tactile sensitivity of children: Effects of frequency, masking, and the non-pacini I psychophysical channel. *Journal of Experimental Child Psychology*, 98:113–130, 2007.
3. Güçlü B., Schepis E.A., Yelke S., Yücesoy C.A., and Bolanowski S.J. Ovoid geometry of the pacinian corpuscle is not the determining factor for mechanical excitation. *Somatosensory & Motor Research*, 23:119–126, 2006.
4. Güçlü B., Gescheider G.A., Bolanowski S.J., and İstefanopulos Y. Population model for vibrotactile spatial summation. *Somatosensory & Motor Research*, 22:239–253, 2005.
5. Güçlü B., Mahoney G.K., Pawson L.J., Smith R.L., and Bolanowski S.J. Localization of merkel cells in the skin: An anatomical model. *Somatosensory & Motor Research*, 25:123–138, 2008.
6. Güçlü B. and Bolanowski S.J. Vibrotactile thresholds of the non-pacini I channel: I. methodological issues. *Somatosensory & Motor Research*, 22:49–56, 2005.
7. Güçlü B. and Bolanowski S.J. Frequency responses of cat rapidly adapting mechanoreceptive fibers. *Somatosensory & Motor Research*, 20:249–263, 2003.
8. Güçlü B., Bolanowski S.J., and Pawson L. End-to-end linkage (eel) clustering algorithm: A study on the distribution of meissner corpuscles in the skin. *Journal of Computational Neuroscience*, 15:19–28, 2003.
9. Shultz C. D., Peshkin M.A, and Colgate E. Surface haptics via electroadhesion: Expanding electro-vibration by johnsen and rahbek. In *Proc. IEEE World Haptics Conference (WHC'15)*, pages 57–62, Evanston, USA, June 2013.
10. Mayer D., Peshkin M., and Colgate E. Fingertip electrostatic modulation due to electrostatic attraction. In *Proc. IEEE World Haptics Conference (WHC'13)*, pages 43–48, Daejeon, South Korea, April 2013.
11. Wijekoon D., Cecchinato M.E., Hoggan E., and Linjama J. Electrostatic modulated friction as tactile feedback: Intensity perception. In *Haptics: Perception, Devices, Mobility, and Communication Lecture Notes in Computer Science*, volume 7282, pages 613–624. 2012.
12. Cheng D. K. *Fundamentals of Engineering Electromagnetics*. Addison-Wesley, 1994.

13. Beebe D.J., Heymel C.M., Kaczmarek K.A., and Tyler M.E. A polyimide-on-silicon electrostatic fingertip tactile display. In *Proc. of the IEEE 17th Annual Conference on Engineering in Medicine and Biology Society*, pages 1545–1546, Montreal, Que, 1995.
14. Vezzoli E., Amberg M., Giraud F., and Lemaire-Semail B. Electroviibration modeling analysis. In *Proc. of the 9th International Conference, Eurohaptics 2014*, pages 369–376, Versailles, France, 2014.
15. Gescheider G. A., Bolanovski S. J., Pope J. V., and Verrillo R. T. A four-channel analysis of the tactile sensitivity of the fingertip: frequency selectivity, spatial summation, and temporal summation. *Somatosensory and Motor Research*, 19(2):114–124, 2002.
16. Kim H., Kang J., Kim K., Lim K., and Ryu J. Method for providing electroviibration with uniformed density. *IEEE Transactions on Haptics*, 8(4):492–496, 2015.
17. Levitt H. Transformed up-down methods psychoacoustics. *The Journal of Acoustical Society of America*, 49(2):467–477, 1971.
18. Tang H. and Beebe D.J. A microfabricated electrostatic haptic display for persons with visual impairments. *IEEE Transactions on Rehabilitation Engineering*, 6(3):241–248, 1998.
19. Summers I. R., Cooper P. G., Wright P., Gratton D. A., Milnes P. M., and Brown B. H. Information from time-varying vibrotactile stimuli. *Journal of Acoustical Society of America*, 102(6):3686–3696, 1997.
20. Linjama J. and Mkinen V. E-sense screen: Novel haptic display with capacitive electroviibration interface. In *Proc. 4th Workshop for Haptic and Audio Interaction Design (HAID'09)*, Dresden, Germany, 2009.
21. Kaczmarek K., Nammi K., Agarwal A., Tyler M., Haase S., and Beebe D. Polarity effect in electroviibration for tactile display. *IEEE Transactions on Biomedical Engineering*, 53(10):2047–2054, 2006.
22. Demarest K. R. *Engineering Electromagnetics*. Prentice Hall, 1998.
23. Leek M. R. Adaptive procedures in psychophysical research. *Perception and Psychophysics*, 63(8):1279–1292, 2001.
24. Yıldız M.Z. and Güçlü B. Relationship between vibrotactile detection threshold in the pacinian channel and complex mechanical modulus of the human glabrous skin. *Somatosensory & Motor Research*, 30:37–47, 2013.
25. Yıldız M.Z., Toker İ., Özkan F.B, and Güçlü B. Effects of passive and active movement on vibrotactile detection thresholds of the pacinian channel and forward masking. *Somatosensory & Motor Research*, 32(4):262–272, 2015.
26. Bau O., Poupyrev I., Israr A., and Harrison C. Teslatouch: Electroviibration for touch surfaces. In *Proc. of the 23rd annual ACM symposium on User interface software and technology (UIST'10)*, pages 283–292, NewYork, USA, 2010.
27. Strong R.M. and Troxel D.E. An electroviibration display. *IEEE Transactions on Man-Machine Systems*, 11(1):72–79, 1970.
28. Kim S.C., Israr A., and Poupyrev I. Tactile rendering of 3d features on touch surfaces. St. Andrews, 2013. UIST'13.
29. Bolanovski S.J., Gescheider G.A., Verrillo R. T., and Checkosky C.M. Four channels mediate the mechanical aspects of touch. *Acoustic Society of America*, 84(5):1680–1694, 1988.
30. Yamamoto T. and Yamamoto Y. Dielectric constant and resistivity of epidermal stratum corneum. *Medical and Biological Engineering*, pages 494–500, 1976.
31. Ehrenstein W. H. and Ehrenstein A. Psychophysical methods. In *Modern Techniques in Neuroscience Research*, pages 1211–1241. Springer Berlin Heidelberg, 1999.